

KLEE pump *KSP*

Contractor and drainage pumps

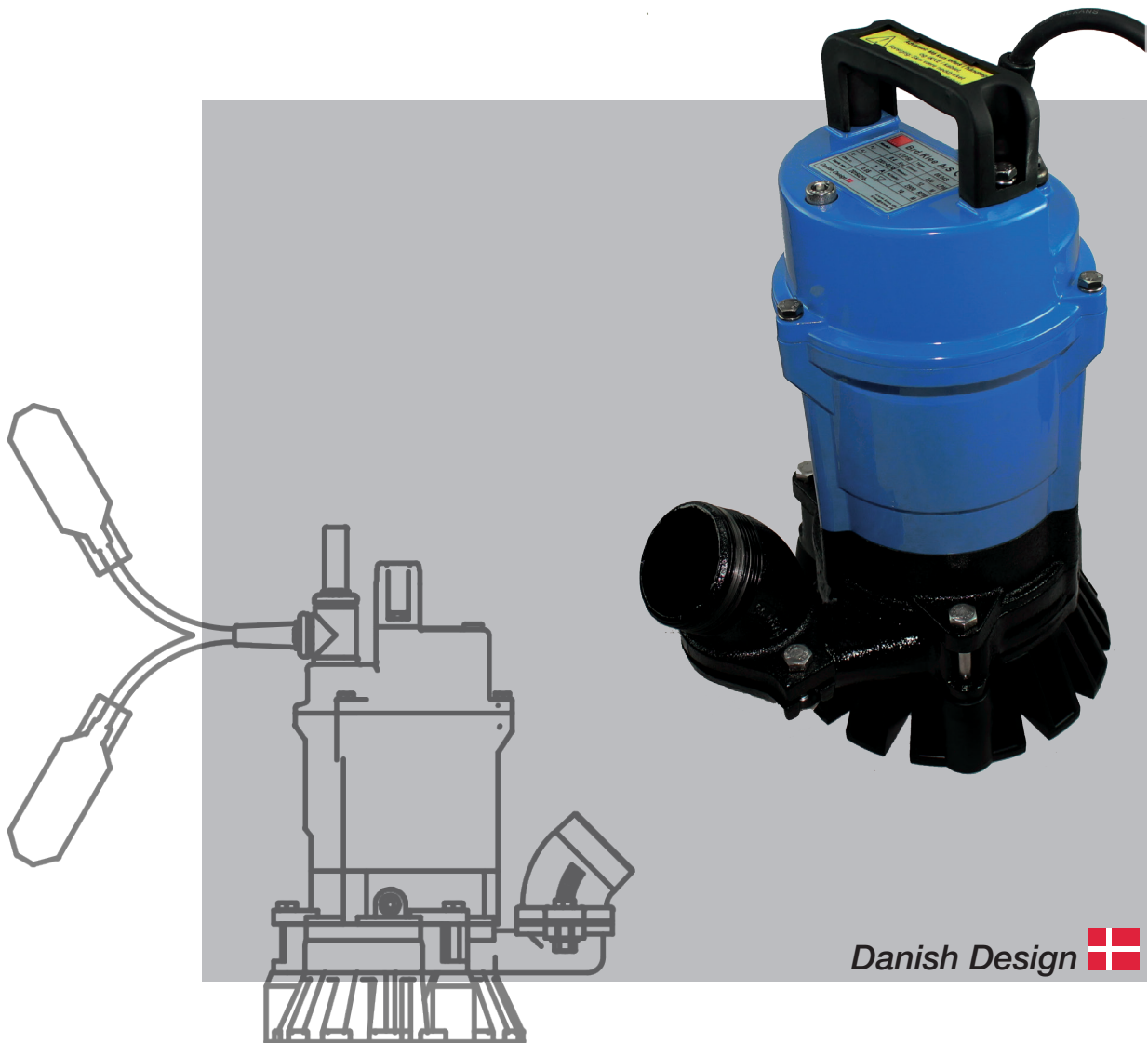

Danish Design 



BRD. KLEE TRADING & ENGINEERING COMPANY

Phone +45 4386 8333 · Fax +45 4386 8388 · e-mail: klee@klee.dk · www.klee.dk



KLEEpump KSP



KLEEpump KSP is a small and effective drainage and contractor pump with a wide range of applications such as excavations or as safety against flooding in basements etc.

Applications:

- Contractor use for disposal of surface water
- Drainage generally with or without wells (basements, residential areas, gardens etc.)
- Dewatering after flooding in, for example in basements (with low suction adaptor)



Multiple types of float switches. Also suitable for narrow wells.

High-efficiency motor with self-resetting thermal device which protects against inappropriate operation and increases longevity.



10 m durable cable with plug on 1-phase models. (version depending on country)



Double mechanical SiC seal mounted in the oil chamber for constant lubrication.

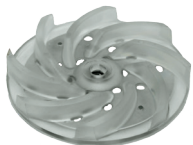

Polyurethane impeller with good resistance against sand and gravel.



A low suction adaptor can be mounted making the pump capable of pumping down to floor level (approx. 3mm).



Agitator which ensures a uniform viscosity and minimizes downtime due to clogging.

Curve:

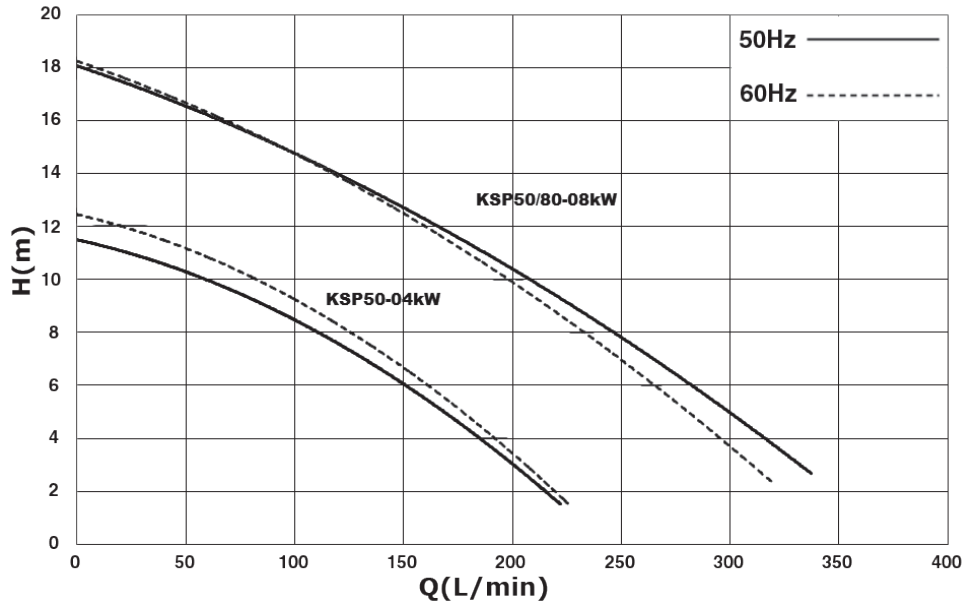

Scale drawing:

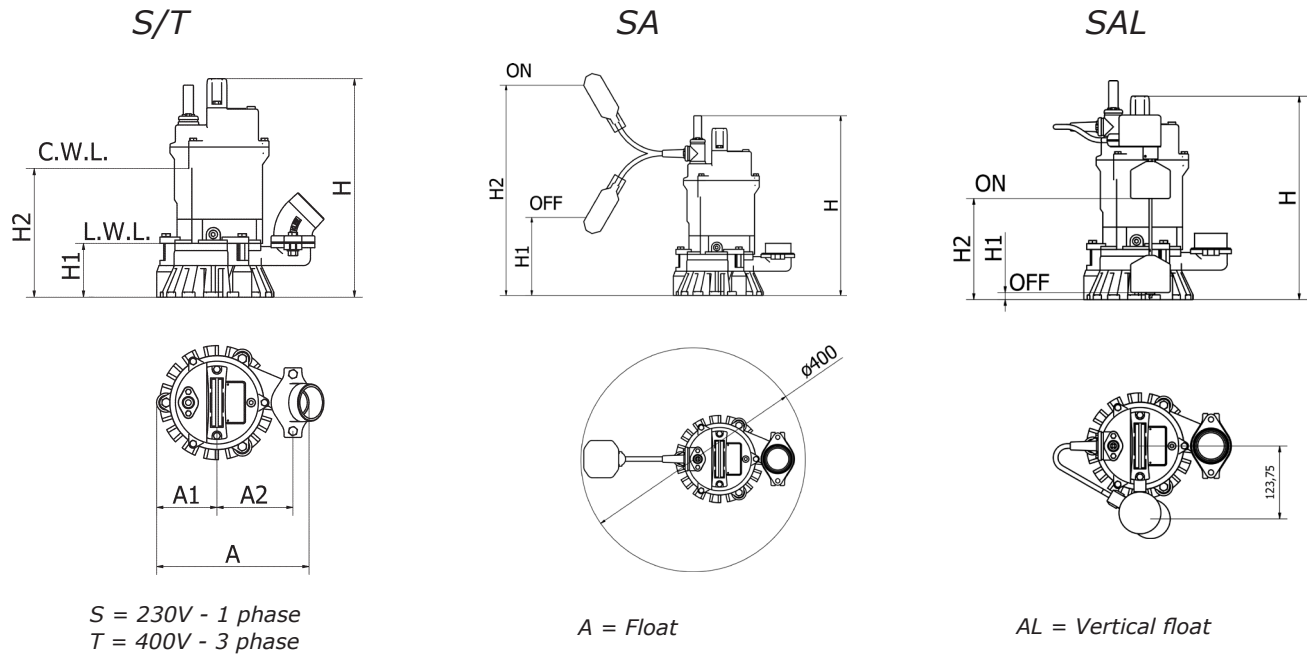

Technical data:

Outlet mm	Model	Version	Effect	Voltage		Dimension (mm)						Weight Kg
			kW	\varnothing	V	A	A1	A2	H	H1	H2	
50	50-5-04-S/T	Manual	0.4	1.3	230/400	249	95	120	343	90	200	12
	50-5-04-SA	Automatic	0.4	1	230	249	95	120	343	200	400	12.3
	50-5-04-SAL	Automatic	0.4	1	230	249	95	120	343	150	230	12.3
50/80	50/80-5-08-S/T	Manual	0.75	1.3	230/400	279	95	135	368	90	225	16
	50/80-5-08-SA	Automatic	0.75	1	230	279	95	135	368	225	425	16.3
	50/80-5-08-SAL	Automatic	0.75	1	230	279	95	135	368	175	255	16.3

All models come with hose connection apart from 50-5-04-S which comes with 45° bend. Other voltages available on request.

Klee offers a wide range of parts and accessories for KSP.

Spare parts:

Cables, impellers, float, bottom sieves, pump houses etc.



Accessories: Hoses, Storz couplings, low suction etc.



KLEE Engineering

Phone: +886 287 523 733 • Fax: +886 287 523 755
info@klee.com.tw • www.klee.com.tw

BRD. KLEE Trading & Engineering Company

Phone: +45 4386 8333 • Fax: +45 4386 8388
klee@klee.dk • www.klee.dk